

# Radius Series Wood Stoves

Australian Owner's Manual • Installation and Operation

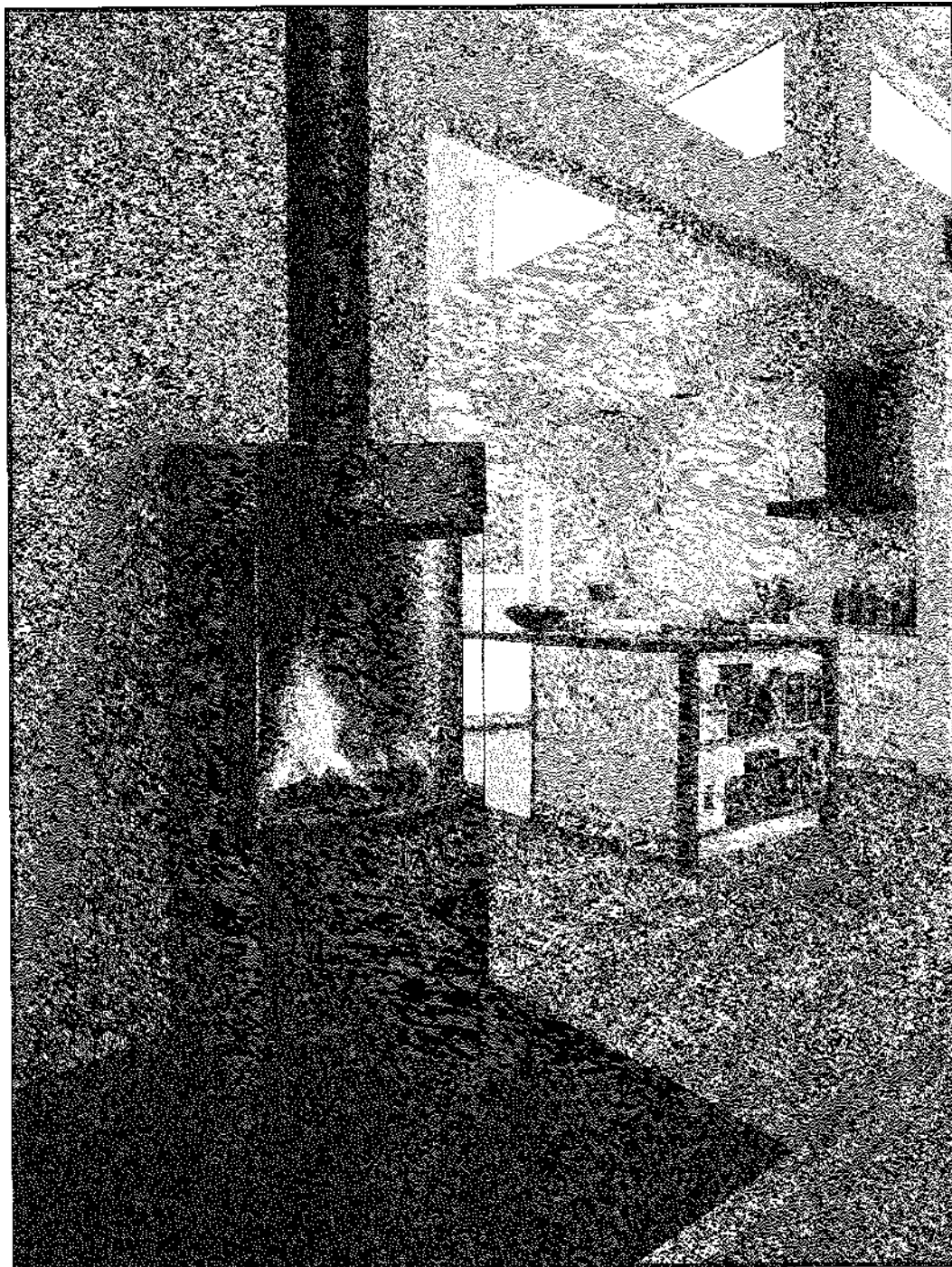

**HEAT GLO.**

No one builds a better fire

NOTE: This product is designed as an intermittent wood burner and not intended to be used as a primary heat source

## Congratulations



### and Welcome to the Heat & Glo Family!

Hearth & Home Technologies welcomes you to our tradition of excellence! In choosing a Heat & Glo appliance, you have our assurance of commitment to quality, durability, and performance.

This commitment begins with our research of the market, including 'Voice of the Customer' contacts, ensuring we make products that will satisfy your needs. Our Research and Development facility then employs the world's most advanced technology to achieve the optimum operation of

our stoves, inserts and fireplaces. And yet we are old-fashioned when it comes to craftsmanship. Each unit is meticulously fabricated and surfaces are hand-finished for lasting beauty and enjoyment. Our pledge to quality is completed as each model undergoes a quality control inspection.

We wish you and your family many years of enjoyment in the warmth and comfort of your hearth appliance. Thank you for choosing Heat & Glo.

#### Serial Rating Plate Example

<p>OVERALL AVERAGE EFFICIENCY BURNING HARDWOOD (WHEN TESTED IN ACCORDANCE TO AS/NZS 4012) 64%</p> <p>AVERAGE PARTICULATE EMISSION FACTOR BURNING HARDWOOD (WHEN TESTED IN ACCORDANCE TO AS/NZS 4013) 0.8 g/kg</p> <p>MAXIMUM AVERAGE HEAT OUTPUT BURNING HARDWOOD 6.5 kw</p> <p>APPROVED FUEL BURN ONLY HARDWOOD WITH A MOISTURE CONTENT LESS THAN 25% (dry basis).</p> <p>Wetbacks are NOT an approved option and must not be fitted.</p> <p>NOTE: Performance may vary from test values depending on actual operating conditions.</p> <p>INSTALLATION DATE    /    /</p> <p>This appliance has been TESTED TO AS/NZS4013 for Hardwood by HRL Technology Report # HCMG/14/066 Date tested:</p>
---

#### INSTALLATIONS TO COMPLY WITH AS/NZS4013 AND WILL REQUIRE A BUILDING CONSENT

**IMPORTANT:** Read all instructions carefully before starting installation. Failure to follow these instructions may result in a fire hazard and will void the warranty.

- Fig. 7.1,8.1,13.1,14.1,14.2 and Table 1,2 relate to installations with tested flue systems; as per AS/NZS 2918:2001 - Appendix F, with a ceiling angle between 0° - 30° inclusive.
- For installations with a ceiling angle greater than 30°, refer to Fig. 14.2 and AS/NZS 2918:2001 4.6.3(b)
- Ceiling Plate may vary in size depending on ceiling angle. Please specify ceiling pitch prior to ordering the ceiling plate.

#### Radius Hardwood Certified

Particulate Emissions = 0.8 g/kg Space Heating Efficiency = 64%

## Table of contents

<b>Technical data</b> .....	4
Installation	
Safety	
Technical data and dimensions	
Type plate	
Dimension sketch for Radius - series	
<b>Installation &amp; Assembly</b> .....	7
Positioning your wood burning stove	
Vertical Venting Horizontal	
Venting Leveling the Unit	
Position near to non-	
flammable walls	
Distance to furniture	
Distance to flammable walls	
Removal of Radius from pallet	
Component Pack	
<b>Instruction for use</b> .....	9
General Use	
Lighting Instructions	
Your First Fire	
Fuels	
Primary Air	
Upper Air Control	
Secondary Air	
Airwash System	
Front Door Handle Operation	
Front Door Seal	
Chimney System	
Drafting	
<b>Maintenance</b> .....	13
Ash Drawer	
Refractory	
Baffle Material	
For Proper burn	
Coated Surfaces	
Cleaning the Glass	
Removal of Refractory	
<b>Troubleshooting</b> .....	15
<b>Service Parts &amp; Accessories</b> .....	16
<b>Warranty</b> .....	18

## Installation

The house owner is responsible for ensuring that all necessary national and local safety measures are observed during installation and fitting and also responsible for observing the fitting and operating instructions detailed in this manual.

When you install any kind of fireplace or stove, you must inform the local authorities. You are also responsible for calling in a chimney sweep to inspect and authorize the installation.

To ensure best-possible functionality and safety for your installation, we advise you to call a professional fitter. Our Hearth and Home Dealer will be able to recommend a qualified fitter in your area. For information on Hearth and Home Dealers, please go to [www.hearthnhome.com](http://www.hearthnhome.com).

All installations must comply with AS/NZS2918:2001.

This product was tested and certified using a default flue kit

**IMPORTANT:** Read all instructions carefully before starting installation. Failure to follow these instructions may result in a fire hazard and will void the warranty.

## Safety

Any changes made to the product by the dealer, installer or user could result in the product and safety functions not functioning as intended. The same applies to the fitting of accessories or extra equipment not supplied by Hearth and Home. This could also be the case if parts that are necessary for the operation and safety of the stove are dismantled or removed.

External surfaces of the appliance get hot during use and can cause burns. Use caution around the unit even when the unit does not appear to be in use. Different materials can hold heat for different lengths of time.

In the event of a chimney fire, keep the front door closed, close all air controls, evacuate the structure and call the local authorities from a safe location.

## Technical data and dimensions

Materials: steel plate, cast iron, galvanized sheet, skamol	
Max. wood length:	30 cm
Weight Radius 300:	ca. 98 kg
Weight Radius 100:	ca. 96 kg
Connecting piece internal diameter:	135 mm
Connecting piece external diameter:	148 mm

## Emissions Test in compliance with AS/NZS 4012/4013

### Basic data for the Radius - series

Overall Efficiency .....	64%
Average particulate emissions: .....	0.8 g/kg
Average Peak Power: .....	8.9 kW
Average Power per setting:	
High .....	6.5 kW
Medium.....	6.0 kW
Low .....	5.1 kW

Note: Be aware of the use of exhaust fans when operating in the same room or space as the appliance, which could affect the draft of the appliance.

## Type plates

All Heat & Glo wood-burning stoves are fitted with a serial plate, that specifies the approval standards.

**NOTE:** This product design intent is for intermittent use and not as a primary heat source.

Dimension Sketch - Radius 100

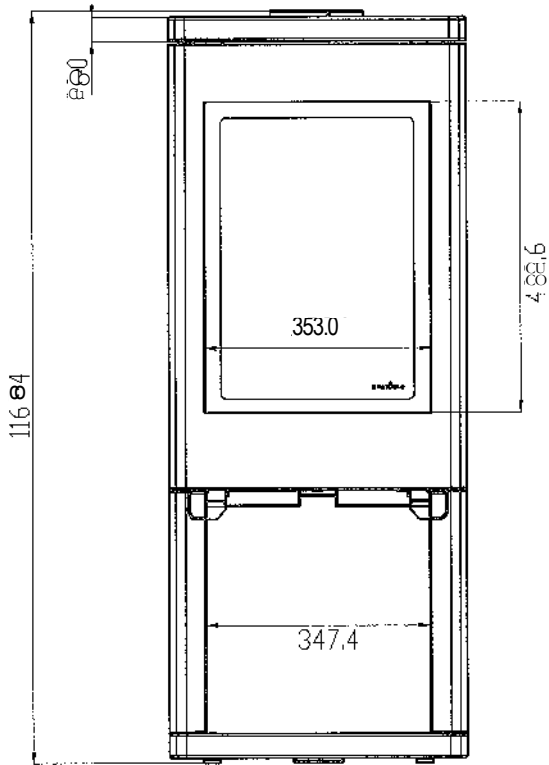

Fig. 5.1: Front of Unit

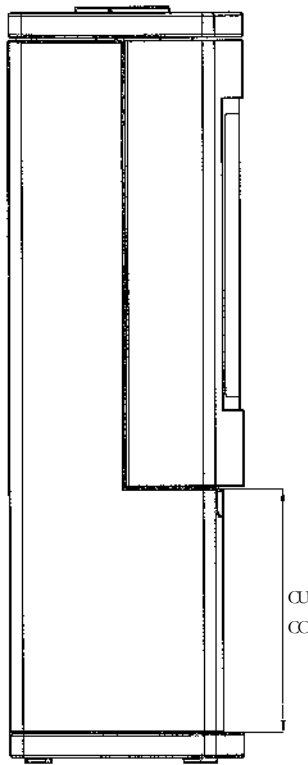

Fig. 5.2: Left Side

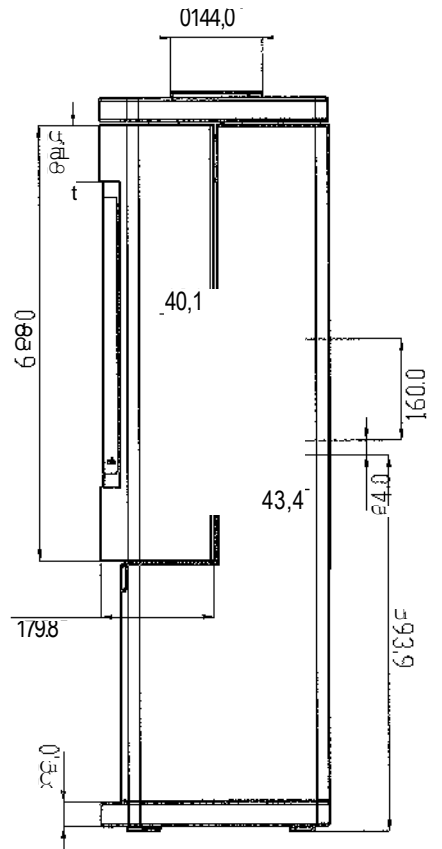

Fig. 5.3: Right Side

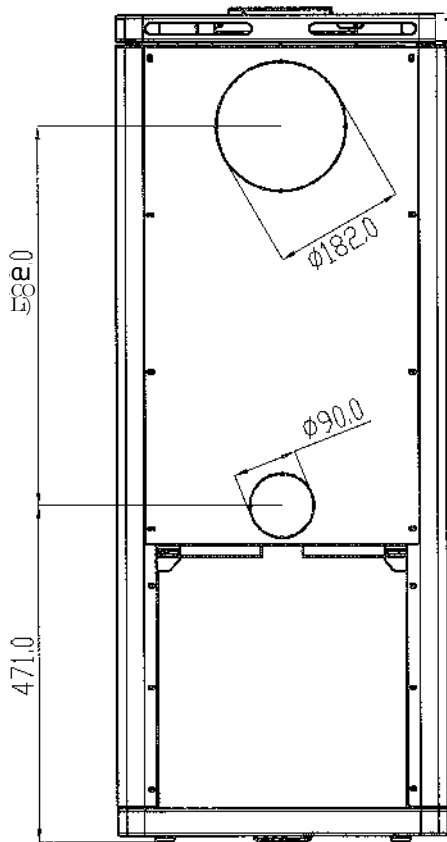

Fig. 5.4: Back of Unit

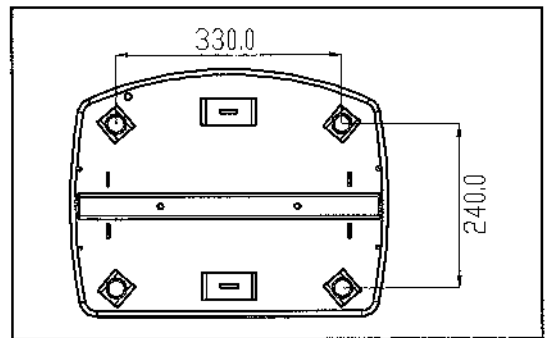

Fig. 5.5: Bottom of Unit

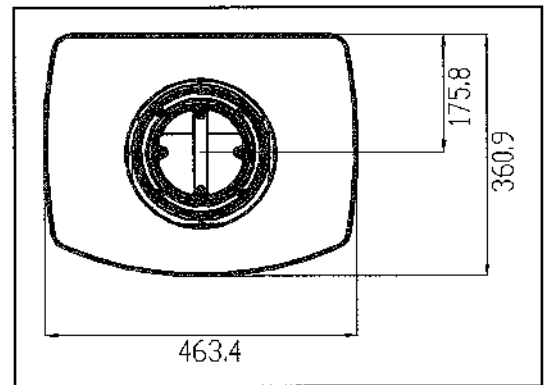

Fig. 5.6: Top of Unit

Dimension Sketch Radius 300

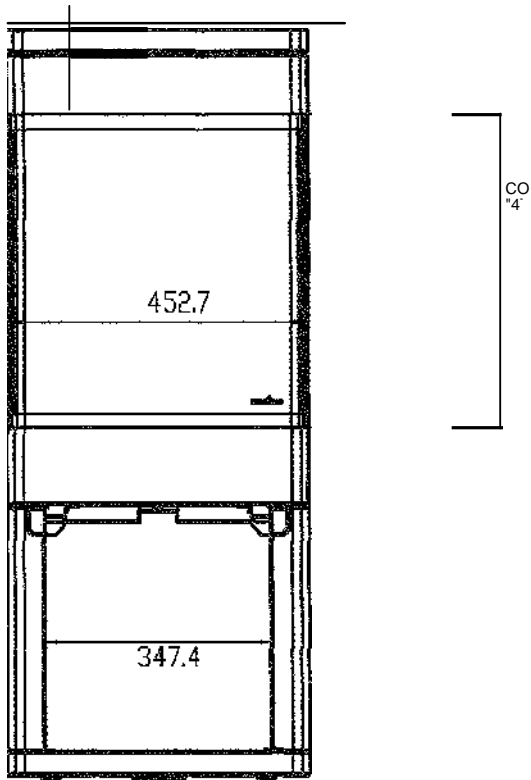

Fig. 6.1: Front of Unit

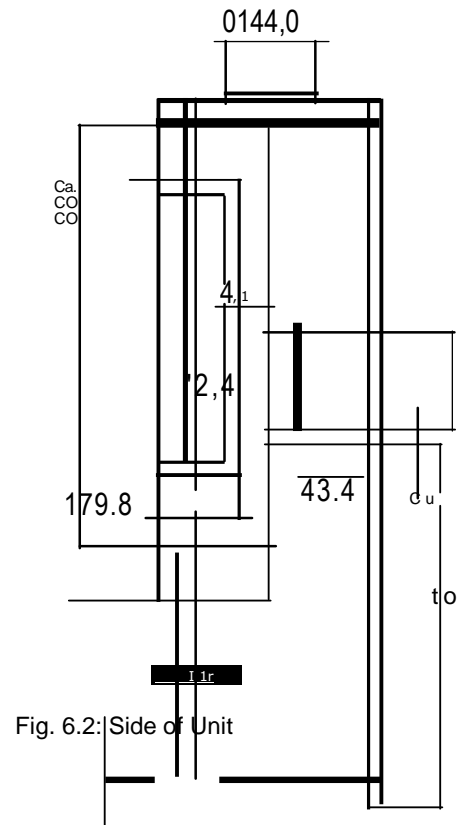

Fig. 6.2: Side of Unit

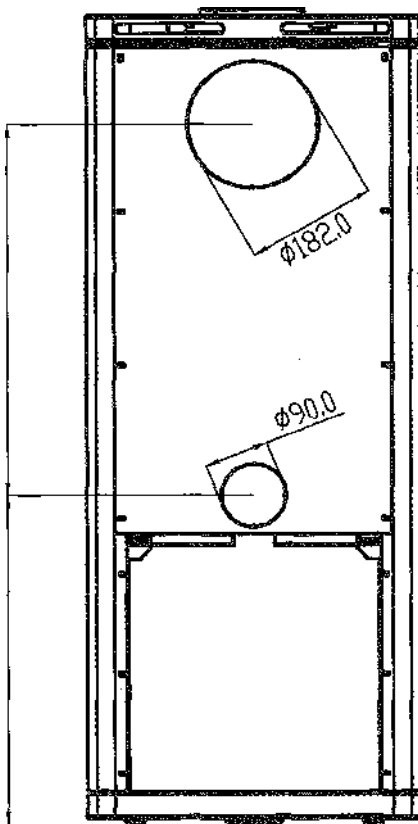

Fig. 6.3: Back of Unit

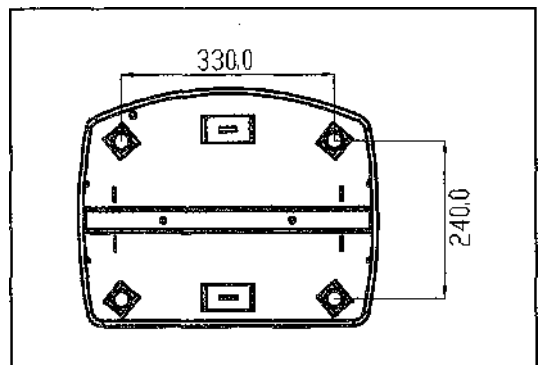

Fig. 6.4: Bottom of Unit

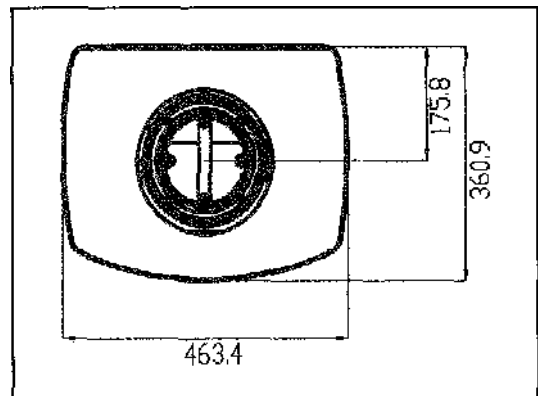

Fig. 6.5: Top of Unit

### A. Positioning Your Wood Burning Stove

The wood burning stove must be set up so the stove, flue connection, flue pipe, and chimney system can be cleaned and serviced. Consideration should also be made when locating the appliance in the home due to the supply of combustion air requirements. Depending on the chosen installation method, supplied combustion air may be taken from the outside using the adapters provided, or through the back of the unit by removing the cover plate on the inlet hole. (To remove the cover or install the outside air adapter, remove the back panel. The cover plate is located near the bottom and retained with four screws.)

Out of the box, the appliance without the additional weight of the venting system or fuel load weighs nearly 100 kilograms. Make considerations for the weight of the system when locating the unit in the desired location. If the load bearing characteristics of the structure are difficult to determine or there is concern that the structure will not adequately support the system, a distribution plate should be used. Contact your Radius Wood Stove dealer with questions.

### B. Vertical Venting & Combustion Air

When venting the appliance vertically, follow the venting manufacturer's instructions and requirements. Slip the cover ring down the flue and set on top of the appliance.

#### Vertical Venting Options (Fig. 7.1)

Standard 150mm Venting: E, B, F

Coaxial venting: F, E, D, A

(Use the items indicated for your installation. Use the bolts provided to attach the components in the order shown.)

When installing F:

- - If installing outside combustion air, turn F to cover the opening at the top of the combustion air plenum.
- - If using room combustion air or coaxial venting, turn F to leave the opening at the top of the combustion air plenum open.

(The outside air connection is located on the lower back of the stove. The 75mm adapter is included in the component pack.)

### C. Horizontal Venting

When venting the unit horizontally, remove the back panel of the unit. Next, remove the cast flue attachment ring in the top of the appliance by removing the four bolts used to secure it in shipping. Remove the rear cover plate that can be seen in the back of the unit once the back panel is removed. Install the rear cover plate over the vertical outlet hole in the top of the unit using the four bolts that were used to secure the cover plate when installed on the rear of the unit. Install the cast flue attachment ring on the rear of appliance using four bolts. Knock out the panel on the back panel so the flue attachment ring can slip through it. Attach the back panel back onto the appliance using

the same fasteners. Install the venting per the venting manufactures specifications. Place the top cover plate (item "C" in Fig. 7.1) from the component pack over the hole in the top of the appliance for a finished look.

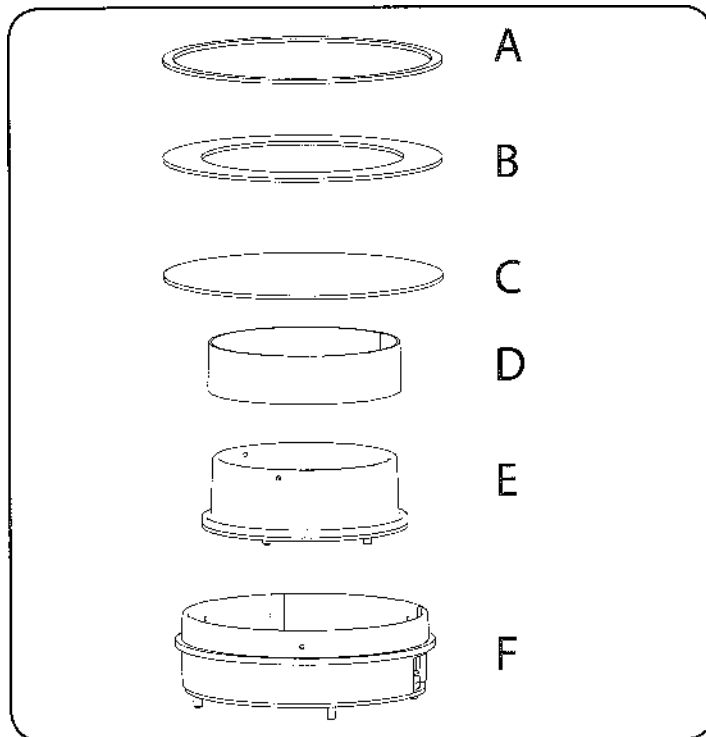

Fig. 7.1

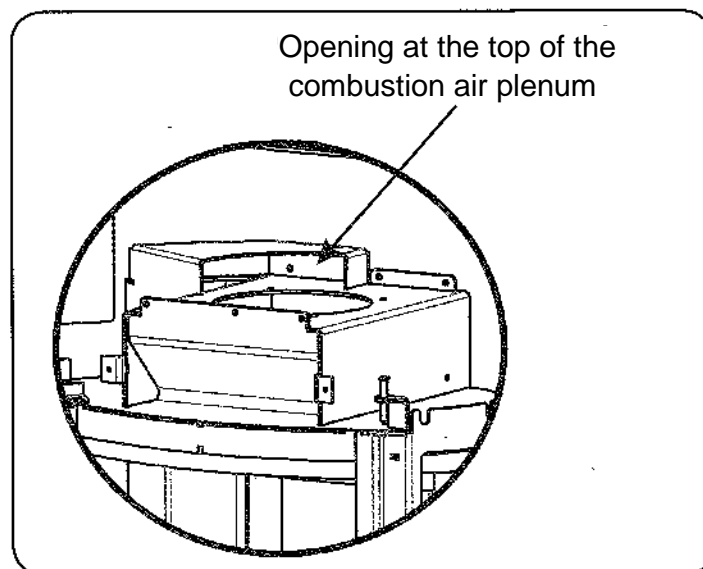

Fig. 7.2

This unit is suitable for installation in a shared flue.

## Leveling the unit

Four leveling bolts have come installed on the unit. Following installation, adjustments can be made to the heights of the four bolts from the top of the base pan. Use a hex head bit to adjust the height of each of the four legs. When in its final state, the unit should be secure and not rock.

## Position near to non-flammable walls

When positioning near a non-flammable wall, we recommend you keep a minimum distance of 50 mm between the rear of the product and the wall for cleaning purposes.

## Distance to furniture: 1000 mm

But please check to avoid furniture or other furnishings being dried out due to being too close to the stove.

## Distance to flammable walls

See. fig. 8.1.

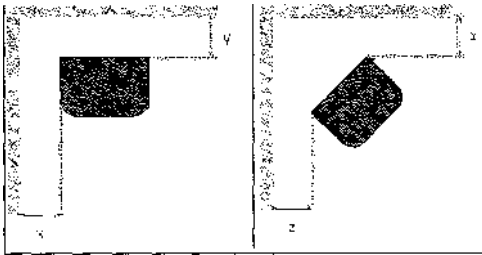

UNIT	DIMENSIONS			HEARTH SIZE IN FRONT
	X (mm)	Y (mm)	Z (mm)	
Radius 100	450	200	150	300mm
Radius 300	450	200	150	300mm

Fig. 8.1

## Minimum Floor Protection Requirements

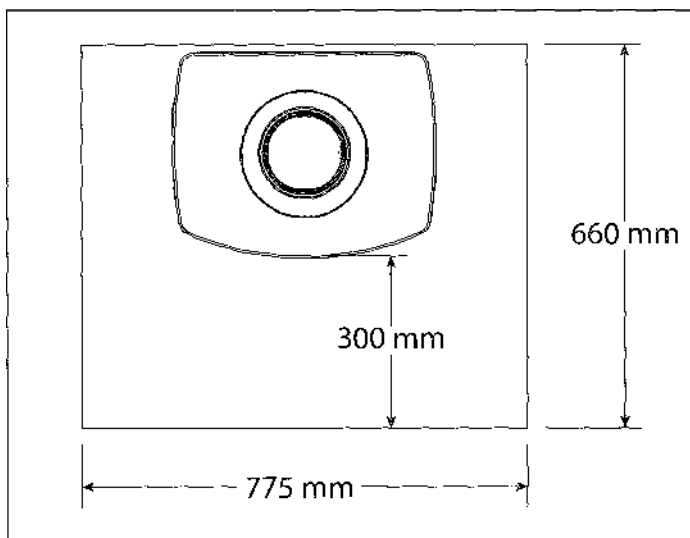

Fig. 8.2

## Component Pack

The component pack contains the following:

- Manual
- Gloves
- Outside air connecting plate
- Top adapter ring
- Top flue cover plate
- Outside air screen

## Removal of Radius from pallet

1. Remove the two 11 mm bolts holding the brackets in the front and rear of the base on the unit, this requires holding the bolt on the bottom side of the pallet as shown in picture below on right
2. Tilt unit back until the front bracket is able to tilt forward and be removed from bottom of unit, repeat tilting forward and removing rear bracket. (the brackets need to swing down and slightly back in order to be pulled from unit)
3. Unit can now be moved off pallet.

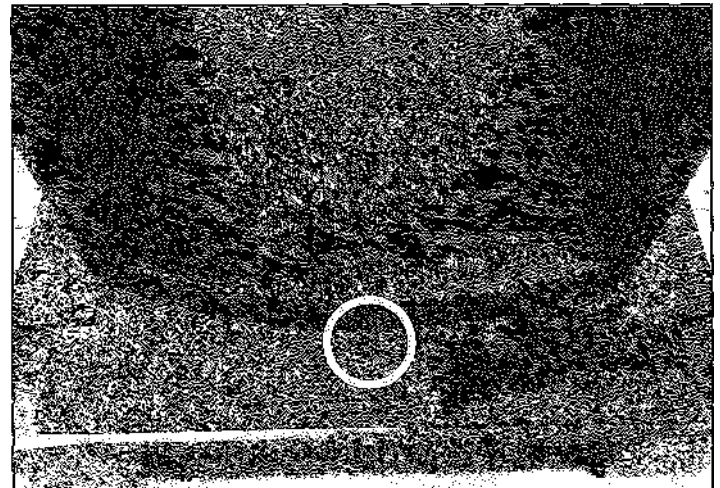

Fig. 8.3



Fig. 8.4



## General Use

The Radius Series Wood Stoves are designed and tested for intermittent use. This means that it is not designed for or recommended to burn continuously for 24 hours.

This is a wood burning stove, the front, sides, and top will get hot. Please use caution when you are near the fire especially when it is burning.

Disposal of ashes and coals should always be in a non-combustible container. Never put coals or embers into a flammable container, even when they do not appear to be hot. Coals can hold heat for extended periods of time and may cause damage if improperly disposed of.

Prior to the start of the burn season or following extended periods of non-use, you should inspect the firebox, flue connections, and chimney system for debris and obstructions. Clean as necessary. Contact your chimney sweep if needed.

Modification to your Radius appliance is prohibited, will void the warranty, and may cause unsafe conditions during use. Certain accessories are approved and available from your local Radius Series Wood Stove Dealer.

Use only approved replacement parts available from your Radius Series Wood Stove Dealer.

## Lighting Instructions

Use paper or lighting briquettes and small pieces of wood to light fire. Place the paper first in the bottom of the fire box and stack the lighting briquettes or small pieces of wood on top of the paper. Do not fill the firebox higher than the holes in the rear of the fire box. **(See Figures on next page).**

Push in both air controls to open. Light the paper and leave the door open slightly. As the small pieces of wood are burning add slightly larger fuel on top of burning fuel and close the door. After 15-30 minutes or when good fire is established, close the lower air control (it is located on the left side) by pulling it out completely. When loading more wood during use, this control may need to be pushed in to add more air under the fire.

## Your First Fire

During the first firing of the Radius it is to be expected to smoke and give off unpleasant fumes. This is caused by the paint curing on the coated surfaces. Make sure the room is well ventilated to reduce the inhalation of these fumes. After this first fire the smoking and unpleasant smell should greatly diminish.

As the paint cures, the rope seal on the door may stick to the face making it difficult to open the front door. To aid in the curing process, open the front door every 5 —10 minutes for the first one to two hours. This will keep the seal from forming a bond to the face as the coating cures completely.

For the duration of this fire keep both air controls in the completely open position to ensure hot burn to cure stove.

## Fuels

The Radius Series wood stoves are designed to burn a wide range of firewood species. In general hardwoods are better for heating since they burn more evenly. When operating the unit with different types of fuels, refer to operating the wood stove section for more information. Consult the internet for specific heating values of different species of firewood.

The optimal size of firewood for the Radius Series wood stove is 25 cm long and 6 cm — 12 cm in diameter when split. Some varieties of fuels may perform better when split smaller. When establishing a fire, it is helpful to have a variety of different diameters in order to heat the flue up quickly and establish the draft.

Fuels should be stored in locations protected from rain and excessive moisture. Well seasoned firewood may take 1 -2 years to dry out. Well ventilated areas protected from environmental elements aid in preparing the fuel faster. If the fuel is stored outside, it is recommended that it is stored inside a few days before use to allow the fuel to warm up to room temperature.

Firewood and combustible items should NEVER be stored below the firebox. Make sure the proper clearance to flammable materials is maintained for all fuel storage. The firewood used should have a moisture level less than 20%. The Radius Series wood stove will yield its best performance if the moisture content is between 15% and 18%. Moisture levels above 20% can have adverse environmental effects because of the inefficient burn. Moisture levels below 15% will burn faster resulting in shorter burn times. To determine whether your fuel is too wet, knock it on a hard surface. If it is too wet, the sound produced will be dull.

Burning wet wood reduces the amount of heat output into your home because it is turning the water into steam and venting it out your chimney rather than producing gases that are burned up in the secondary system. It also increases the amount of soot on the glass and in the chimney system. It is inefficient and produces pollution. Improper use including the use of illegal fuels may cause pollution and can damage the appliance. Improper use will void the manufactures warranty. Never burn treated or painted wood, chipboard, glued or laminated materials, wood from salt water, plastics, trash, or chemically treated paper.

Fig.10: Proper Fill and Startup Configuration

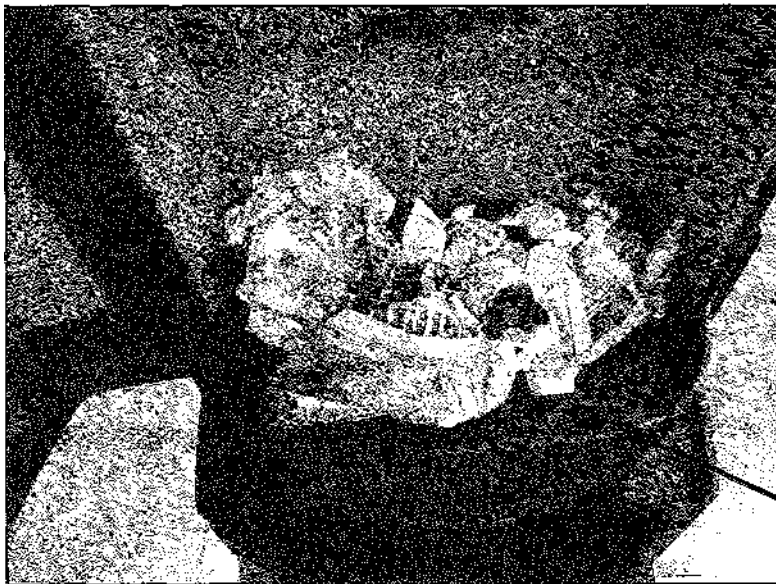

Fig. 10.1: Add paper to back of firepot making sure to not block lower air inlet with paper.

Lower Intake Holes

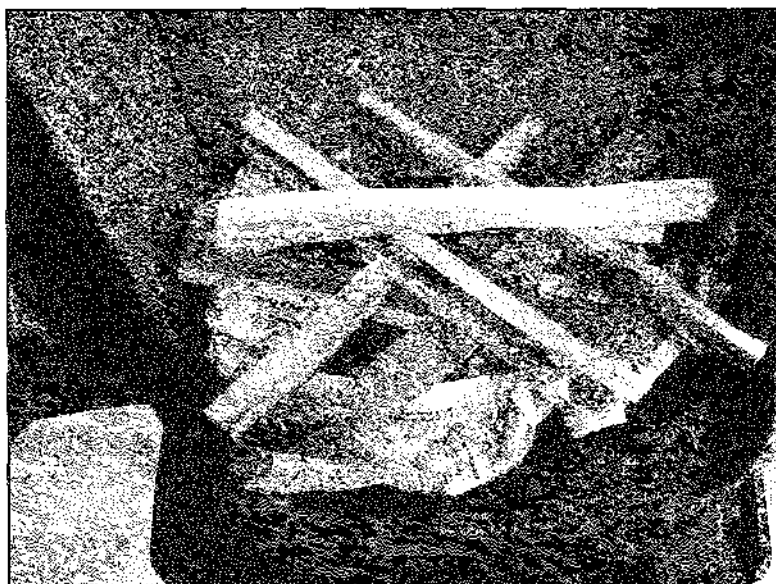

Fig. 10.2: Add small pieces of wood on top of paper allowing for air flow between pieces.

Secondary Holes



Fig. 10.3: Add larger log on top of pile making sure it does not go above the upper intake holes.

## Primary Air (Lower it Control)

(Figure 11.1)

The primary air is controlled by the lever on the left side of the appliance. When the control arm is pulled out, less air is allowed into the firebox below the fire. When the control arm is pushed in, maximum air is allowed in under the fire. This lever is to be used during start up and refueling. If this air control remains open (pushed in) then you will have reduced burn times or a potential to overheat the appliance.

## Upper it Control (Figure 11.1)

The upper air control is controlled by the lever on the right side of the appliance. When the control arm is pulled out, less air is allowed into the firebox through this system. When the control arm is pushed in, maximum air is allowed through the system. The function of this air control is to regulate the burn rate of the fire and provide air for the air wash system to keep the glass clean.

When the upper air control is closed and air is reduced to the air wash system, the glass will soot up. This is normal and to be expected. To help clean the glass off, add additional fuel to the fire, pull out the upper air control and pull out the lower air control lever for 15-30 minutes to establish a hot fire. A hot fire with the upper air control open will aid in cleaning the glass.

Fig. 11.1: Air Controls

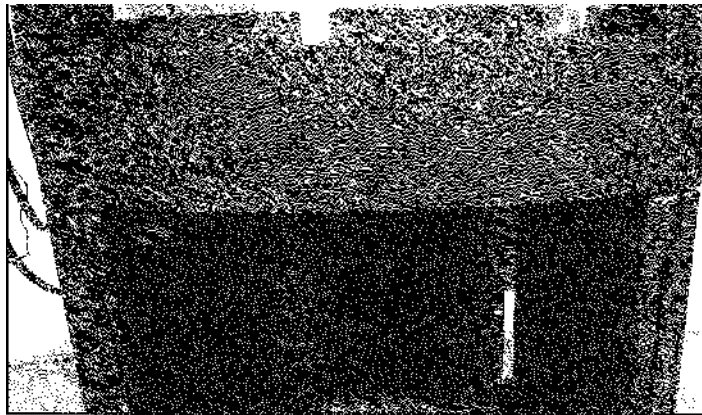

Lower (primary) Air  
Intake Control

Upper (secondary)  
Air Intake Control

## Secondary Air (holes in rear of firebox)

This unit is equipped with a secondary combustion system that cannot be regulated. The purpose of this secondary system is to provide air that will mix with the combustion gasses and burn them. This reduces the amount of debris and gasses being let out into the environment ensuring a clean burn.

## Airwash System

An air wash system is built into the appliance and is controlled by the air control lever on the right side of the appliance. Even with this air wash system, the glass panes will get dirty and have build up. This is normal and can be cleaned using a simple glass cleaner. Alternate glass cleaning products specifically designed for cleaning glass panes on wood burning stoves may be available from your dealer. Contact them directly for product availability.

## Front Door Handle Operation

(Figure 11.2)

To open the front door, pull the lever located on the right side of the unit upwards (be sure to wear the glove provided if the unit is hot). Carefully swing the door open from right to left. To close the door swing it shut from left to right and close by pushing the handle down. When securing the front door closed, make sure the roller on the handle is beyond the ramp catch located on the side of the unit.

Fig. 11.2: Door Handle Operation

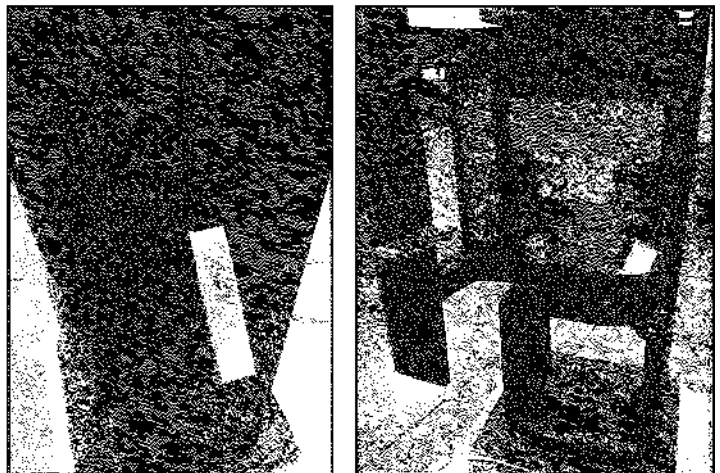

1- Pull side of handle away  
from unit.

2- Then swing door open to the  
left.

## Front Door Seal

The front door has a non-combustible rope which creates a tight seal for the firebox. The first time you open the front door and close it, the gasket may be stiff and the door difficult to close. Following the first fire, the gasketing will relax which will allow the door to be closed easily for normal use which provides a tight seal. This seal is critical for proper air regulation in the firebox for safe and efficient burn. Though this material is a high quality material specifically designed for wood burning appliances, it is subject to normal wear and tear and should be replaced if burn times are reduced or there is concern of leakage. The seal is subject to damage from excessive cleaning or by debris being closed in the door.

If there is a concern of leakage, use a thin piece of paper, place against the gasket in the area of concern, close the door and latch shut, then gently tug on the paper. If the paper comes right out without any resistance, the seal should be replaced.

## Chimney System

A chimney or flue system is required to run your wood stove safely and efficiently. When a fire is started in the fire box hot gases are released and exit the firebox into the chimney system. These hot gases heat up the chimney system and create a vacuum in the firebox or commonly referred to as drafting. As a result, more air is pulled into

the firebox through the air openings. When more air is pulled into the fire, the fire burns hotter and is a cleaner burn. This also means that the burn time is shorter but more heat is generated to heat the living space and the glass stays cleaner. When the air controls are adjusted and reduced, the fire will slow down. This lowers the draft and as a result, the burn times are longer.

When lighting the appliance, it is important to get a hot fire as quick as possible to establish the draft in the system for an efficient and clean burn. There are many different types of chimney systems, check with your local authority for more details and follow all regulations in your area.

## Drafting

Weather and chimney location can affect the draft of your stove resulting in different performance settings. For windy conditions, the draft may be higher which will result in changing the air control settings for the same performance. In areas where high wind is common, a damper may need to be installed in the flue pipe to best control the appliance. Performance can also be influenced by changes in humidity including fog. Adjust the air controls as needed to achieve the desired heat output of your Radius wood burning stove.

Figure 12.1

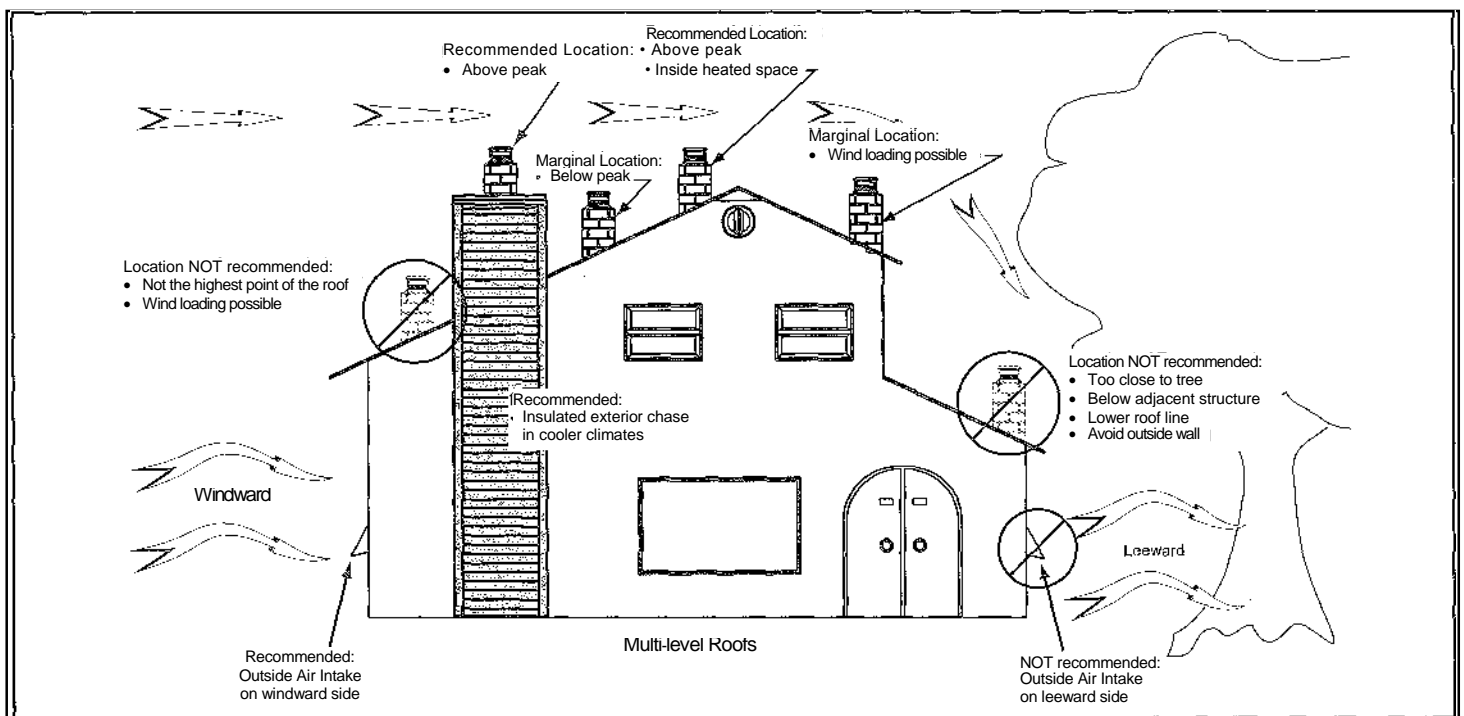

## Ash Drawer

(Figure 13.1)

Before attempting any maintenance on the unit ensure that the unit is cold and has no embers in the firebox. To access the ash drawer open the front door. The drawer is located under the firebox. Before removing pan empty ash from firebox into the pan.

To do this open the grate at the bottom of the firepot by pushing the primary air control lever on the left side all the way in until all holes are open. Then gently sweep ash through the grate into the ash drawer below. Then, pull the primary lever forward to close the grate so that only the two small holes in the back of the unit are open.

Then remove the ash pan drawer and empty into noncombustible container. Never attempt to open ash pan when stove is lit.

Figure 13.1: Ash Drawer Maintenance



1- Push in primary air control to turn grate clockwise to open all grate holes. After all holes are open, push ash through grate to drawer below.

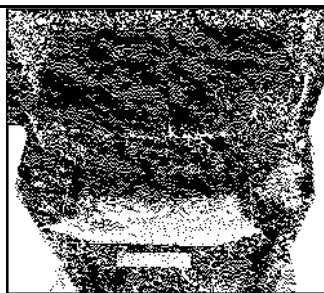

2- Remove drawer by pulling out and empty into qualified container.

## Refractory

The firebox is lined with molded refractory firebrick. The refractory protects the outside of the appliance and retains the heat necessary for a clean efficient burn. The material is a porous ceramic material that can break from abuse. Occasionally, surface cracks may propagate from normal use through the heating and cooling cycle. Surface cracks are normal and should only be a concern when the crack causes the refractory to not remain in place on its own.

## Baffle Material

There are two baffle plates in the top of the unit. The purpose of these plates is to restrict and direct the combustion gases to allow for complete combustion of the gasses prior to exiting the firebox and entering the flue. The lower baffle plate is supported on each side by the side refractory, it is notched on either side to allow proper placement.

The upper baffle panel is supported by two brackets, one on each side of the top of the firebox. During annual chimney maintenance, these two baffle panels must be removed prior to sweeping. Not doing so will result in broken panels. Similar to the refractory panels lining the inside of the firebox, the baffle panels are subject to wear and tear and are subject to warranty limitations.

## Proper Burn

- Remove ash from firebox and ash pan regularly to ensure proper air supply
- Use only 1-3 pieces of wood quartered and placed to optimize air flow (see Figure 10.2)
- ® Adjust the upper air control to ensure that enough air is being supplied to the firebox, there should always be a visible flame with minimal smoke
- ® Fuel should never be stacked above the upper air inlets (see Figure 10.3)

## Coated Surfaces

To clean the stove dust with a lint-free cloth or cleaning device. If the topcoat is damaged it is possible to purchase a repair spray from your local dealer. It is possible that this spray may be slightly different from the original coat. For best results, use repair spray in wide area in order to create a subtle transition from one color to the next. For safety purposes apply spray when stove is cold, the difference in color may be very noticeable when first applied. However, after firing again it should match very close to original color.

## Cleaning the Glass

This stove is designed to minimize soot build-up. To attain this the stove must be burned properly, see section For Proper Burn.

However even when burned properly a slight buildup of soot can occur. To clean you can use dry cloth and regular glass cleaner or specialized stove glass cleaning products.

## Removal of Radius refractory for service or rear venting conversion.

Refractory that has been burned is fragile and must be handled carefully to prevent breakage.

Remove Ash Drawer and set aside.

1. Using a pair of pliers; remove pin that secures the Firepot
2. Plate to the Primary control damper. This can be accessed in the ash drawer cavity below the firebox.

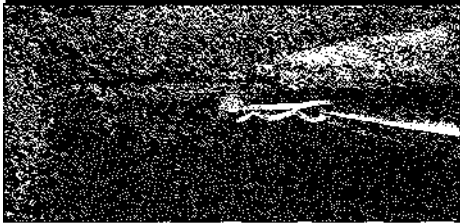

3. Lift out the Firepot Plate and then the Firepot.



4. Lift Baffle (Top piece) slightly and remove left and right sides then the Lower Back Refractory.

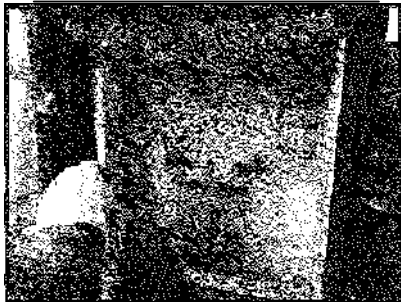

- 5.



Remove the Baffle by lowering the front and pulling out. Be careful to not let the Upper Rear Refractory fall.



6. Remove the Upper Rear Refractory. If you are converting to rear vent, discard the Upper Rear Refractory

Installation is the reverse of the removal.

## Smoke escaping

- Damp wood
- Chimney not drawing properly
- Chimney is not properly dimensioned for the stove
- Check if the smoke gas pipe/chimney are blocked
- Is the chimney the right height for its surroundings?
- At rear outlet, check that the flue pipe does not obstruct the chimney draught
- Vacuum in room
- The door is opened before the embers have burned down sufficiently

## Wood burning too quickly

- The air valves are set incorrectly
- The baffle plates are incorrectly mounted or missing
- Inferior firewood (waste wood, pallets etc.)
- Chimney too large

## Soot build-up on glass

- Incorrect secondary airflow setting
- Excessive primary air
- Damp wood
- Wood pieces too large on lighting

- Inferior firewood (waste wood, pallets etc.)
- Chimney not drawing sufficiently
- Vacuum in room

## Excessive soot build-up in chimney

- Poor burning (more air required)
- Damp wood

## The surface of the stove is turning grey

- Overheating (see instructions for heating)

## Poor heating performance of stove

- Damp wood
- Not enough wood
- Inferior wood quality with low fuel value
- Baffle plates are not fitted correctly Odor coming from stove
- The lacquer on the stove hardens when you use the stove for the first time; this can cause an odor. Open a window or a door for ventilation, and make sure the stove is heated up sufficiently to avoid odors later.
- When heating up and cooling down, the stove may make some clicking noises. These are due to the huge temperature differences to which the material is exposed and do not indicate any product defects.

Start Fire Problems	Possible Cause	Solution
Can't get fire started Excessive smoke or spillage Burns too slowly Smolders, sizzles	Not enough kindling/paper or no kindling/paper	Use dry kindling, more paper. Arrange kindling & wood for air movement.
	Not enough air for fire to ignite	Check for restricted cap/shroud
		Open outside air kit (if installed).
		Check for flue blockage.
		Check for adequate vent height (refer to chimney assembly section).
	Wood condition is too wet, too large	Use dry, seasoned wood (refer to wood fuel section).
	Bed of coals not established before adding wood	Start with paper & kindling to establish bed of coals (refer to starting fire section).
Flue blockage such as birds' nests or leaves in termination cap	Have chimney inspected for creosote and cleaned by a certified chimney sweep.	
Down draft or negative pressure Competition with exhaust devices	Do not use exhaust fans during start-up.	
	Open window below the appliance towards the wind.	
Fire burns too fast	Extremely dry or soft wood	Mix in hardwood.
		Mix in less seasoned wood after fire is established (refer to wood fuel section).
	Overdrafting	Check for correct vent height; too much vertical height creates overdrafting.
		Check location of vent termination (refer to chimney requirements section).
Ash pan may not be closed completely	Close ash pan.	



No one builds a better fire

Service Parts

Wood Stove

**RADIUS-100**

Beginning Manufacturing Date: Sept 2013

Ending Manufacturing Date: Active

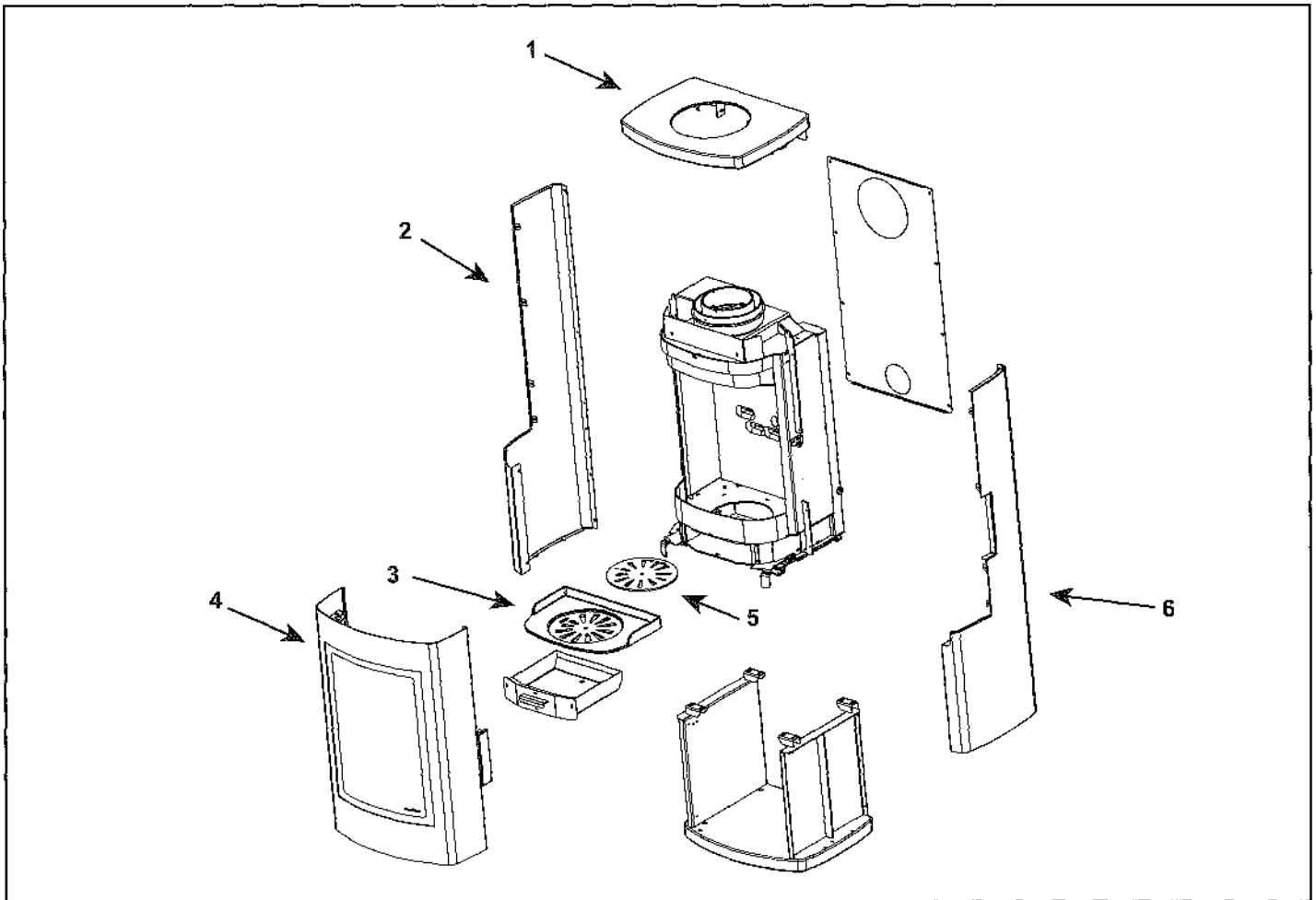

IMPORTANT: THIS IS DATED INFORMATION. Parts must be ordered from a dealer or distributor. **Hearth and Home Technologies** does not sell directly to consumers. Provide model number and serial number when requesting service parts from your dealer or distributor.

ITEM	DESCRIPTION	COMMENTS	PART NUMBER
1	Top		MG08-181
2	Side Panel, Left		7G08-551
3	Cast Firepot		7076-332
4	Door Assembly		7076-008
	Door Handle Assembly		7076-018
	Door Rope		IG08-041
	Glass		IG08-011
5	Firepot Plate		7076-023
6	Side Panel, Right		MG08-551
	Refractory Side Door		IG08-091
	Refractory Assembly		MG08-511
	Black Door Handle Cover		7G08-751
	Pedestal Cover		MG08-501





No one builds a better fire

C3 ■ 11 ■ IMMIN--  
**Service Parts**  
**Wood Stove**

**RARIUS-300**

Beginning Manufacturing Date: Sept 2013  
 Ending Manufacturing Date: Active

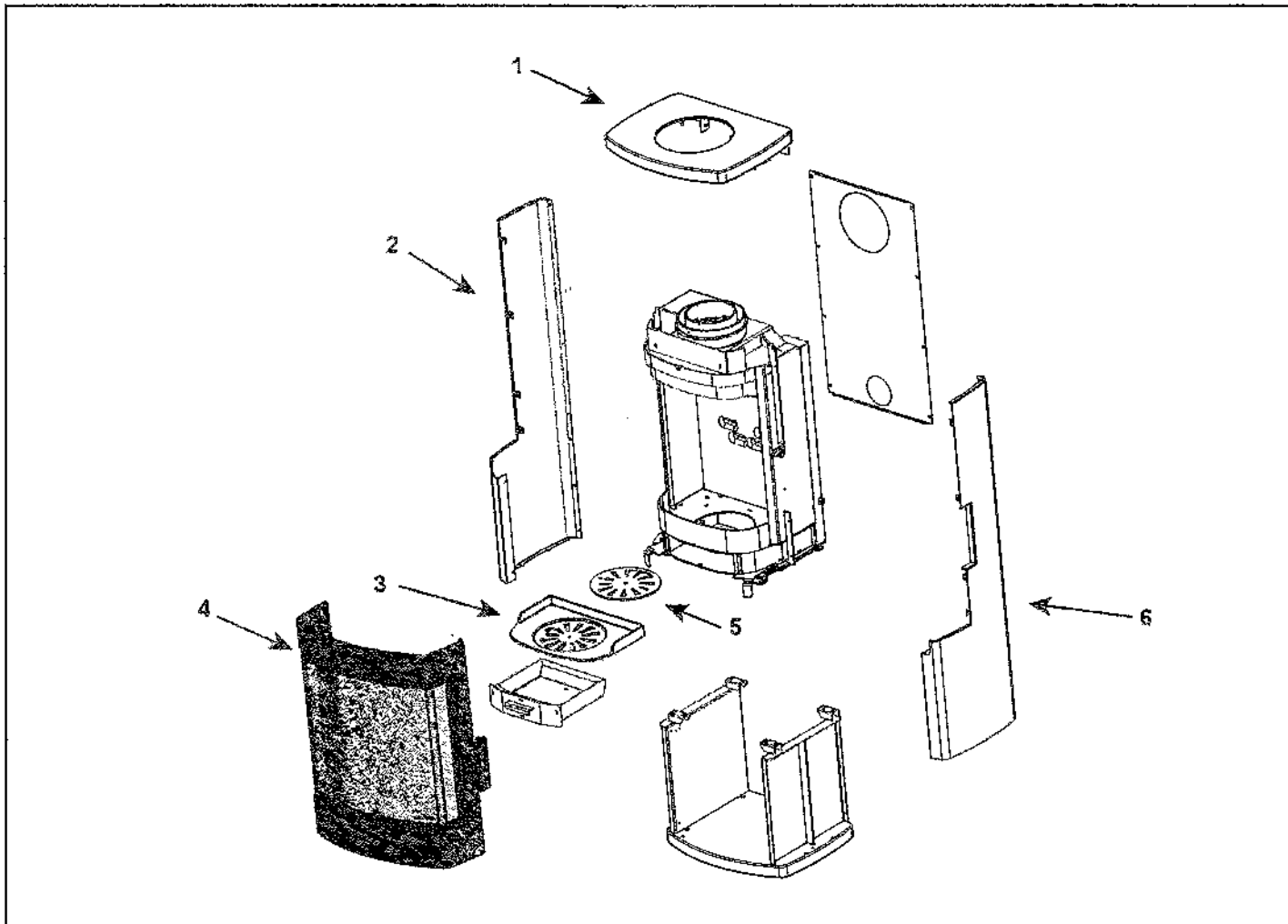

IMPORTANT: THIS IS DATED INFORMATION, Parts must be ordered from a dealer or distributor. Hearth and Home Technologies does not sell directly to consumers. Provide model number and serial number when requesting service parts from your dealer or distributor.

ITEM	DESCRIPTION	COMMENTS	PART NUMBER
1	Top		MG08-181
2	Side Panel, Left		7G08-551
3	Cast Firepot		7076-332
4	Door Assembly		7076-007
	Door Handle Assembly		7076-018
	Door Rope		1G08-041
	Glass		7075-125
5	Firepot Plate		7076-023
6	Side Panel, Right		MG08-551
	Refractory	by	MG08-511
	Black Door Handle Cover		7G08-751
	Pedestal Cover		MG08-501

HEARTH 116 - HOME technologies

**AUSTRALIAN WARRANTY INFORMATION**

Hearth & Home Technologies Inc (HHT)  
1445 N. Highway I Colville, WA 99114 I (509-684-3745)

HHT extends the following manufacturer's warranty for HHT gas, wood, pellet, coal and electric hearth appliances that are purchased from an HHT authorized dealer.

HHT warrants to the original owner of the HHT appliance at the site of installation, and to any transferee taking ownership of the appliance at the site of installation within two years following the date of original purchase, that the HHT appliance will be free from defects in materials and workmanship at the time of manufacture.

After installation, if covered components manufactured by HHT are found to be defective in materials or workmanship during the applicable warranty period, HHT will, at its option, repair or replace the covered components. HHT, at its own discretion, may fully discharge all of its obligations under this manufacturer's warranty by replacing the product itself or refunding the verified purchase price of the product itself. The maximum amount recoverable under this warranty is limited to the purchase price of the product. This warranty is subject to conditions, exclusions and limitations as described below.

Warranty coverage begins on the date of original purchase. In the case of new home construction, coverage under this manufacturer's warranty begins on the date of first occupancy of the dwelling or six months after the sale of the product by an independent, authorized HHT dealer/ distributor, whichever occurs earlier. The warranty period for this manufacturer's warranty shall commence no later than 24 months following the date of product shipment from HHT, regardless of the installation or occupancy date. The manufacturer's warranty period for parts and labor for covered components is produced in the following table.

The term "Limited Lifetime" in the table below is defined as: 20 years from the beginning date of warranty coverage for gas appliances, and 10 years from the beginning date of warranty coverage for wood, pellet and coal appliances. These time periods reflect the minimum expected useful lives of the designated components under normal operating conditions.

Warranty		Gas	Wood	Pellet	Coal	Electric	Venting	Components Covered
1 Year		X	X	X	X	X	X	All parts and material except as covered by Conditions, Exclusions, and Limitations listed
2 years				X	X	X		Igniters, electronic components, glass
		X	X	X	X	X		Factory-installed blowers Molded refractory panels
3 years				X				Fire pots and Burn pots
5 years or 1 year				X	X			Castings and baffles
7 years	3 years		X	X	X			Manifold tubes, HHT chimney and HHT ea
10 years	1 year	X						Burners, logs and refractory
Limited Lifetime	3 years	X	X	X	X	X		Firebox and heat exchanger
90 Days		X	X	X	X	X	X	All replacement parts beyond warranty period

**OTHER RIGHTS**

The HHT manufacturer's warranty is in addition to other rights and remedies that you may have under Australian law.

Our goods come with guarantees that cannot be excluded under the Australian Consumer Law. You are entitled to a replacement or refund for a major failure and for compensation for any other reasonably foreseeable loss or damage. You are also entitled to have the goods repaired or replaced if the goods fail to be of acceptable quality and the failure does not amount to a major failure.

**WARRANTY CONDITIONS AND EXCLUSIONS:**

- The HHT manufacturer's warranty only covers HHT appliances that are purchased through an HHT authorized dealer or distributor. A list of HHT authorized dealers is available on the HHT branded websites.
- This warranty is only valid while the HHT appliance remains at the site of original installation.

**WARRANTY EXCLUSIONS:**

This HHT manufacturer's warranty does not cover the following:

- Changes in surface finishes as a result of normal use. As a heating appliance, some changes in color of interior and exterior surface finishes may occur. This is not a flaw and is not covered under warranty.
- Damage to printed, plated, or enamelled surfaces caused by fingerprints, accidents, misuse, scratches, melted items, or other external sources and residues left on the plated surfaces from the use of abrasive cleaners or polishes.
- Repair or replacement of parts that are subject to normal wear and tear during the warranty period. These parts include: paint, wood, pellet and coal gaskets, firebricks, grates, flame guides, light bulbs, batteries and the discoloration of glass.
- Minor expansion, contraction, or movement of certain parts causing noise. These conditions are normal and complaints related to this noise are not covered by this warranty.
- Damages resulting from: (1) failure to install, operate, or maintain the appliance in accordance with the installation instructions, operating instructions, and listing agent identification label furnished with the appliance; (2) failure to install the appliance in accordance with local building codes; (3) shipping or improper handling; (4) improper operation, abuse, misuse, continued operation with damaged, corroded or failed components, accident, or improperly/incorrectly performed repairs; (5) environmental conditions, inadequate ventilation, negative pressure, or drafting caused by tightly sealed constructions, insufficient make-up air supply, or handling devices such as exhaust fans or forced air furnaces or other such causes; (6) use of fuels other than those specified in the operating instructions; (7) installation or use of components not supplied with the appliance or any other components not expressly authorized and approved by HHT (8) modification of the appliance not expressly authorized and approved by HHT in writing; and/or (9) interruptions or fluctuations of electrical power supply to the appliance.
- Non HHT venting components, hearth components or other accessories used in conjunction with the appliance.
- Any part of a pre-existing fireplace system in which an insert or a decorative gas appliance is installed.
- Removal, installation, reinstallation, set up or any other costs associated with a claim including travel and shipping charges for parts
- HHT's obligation under this warranty does not extend to the appliance's capability to heat the desired space. Information is provided to assist the consumer and the dealer in selecting the proper appliance for the application. Consideration must be given to appliance location and configuration, environmental conditions, insulation and air tightness of the structure.

**This warranty is void if:**

- The appliance has been over-fired or operated in atmospheres contaminated by chlorine, fluorine, or other damaging chemicals. Over-firing can be identified by, but not limited to, warped plates or tubes, rust coloured cast iron, bubbling, cracking and discoloration of steel or enamel finishes.
- The appliance is subjected to prolonged periods of dampness or condensation.

There is any damage to the appliance or other components due to water or weather damage which is the result of, but not limited to, improper chimney or venting installation.

**HOW TO CLAIM**

- To make a claim against this warranty, contact your local distributor during regular business hours. See addresses below for a dealer nearest you. (Vic) Pty Ltd ACN 005 872 159 (Jetmaster).
- Additional service fees may apply if you are seeking warranty service from a dealer other than the dealer from whom you originally purchased the product.
- Check with Jetmaster in advance for any costs to you when arranging a warranty call. Travel and shipping charges for parts are not covered by this manufacturers' warranty.
- HHT and Jetmaster will assess your claim. HHT or Jetmaster may need to inspect the product as part of the assessment of your claim. If the product requires inspection, **HHT** or Jetmaster will discuss with you the best way for this to occur.
- To make a claim under this manufacturer's warranty, you must be able to prove when you purchased the product. The easiest way to do this is through your original proof of purchase, for example your invoice or receipt. However, if you do not have your original proof of purchase HHT or Jetmaster may accept other evidence of the date of purchase.

**Local Distributors:**

<b>Melbourne</b>	Jetmaster	44 Swan Street	Richmond 3121	(03) 9429-5573
<b>Perth</b>	Fireplace Corner	277 Lord Street	East Perth 6000	(08) 9228-2600
<b>Sydney</b>	Jetmaster	10 Martin Avenue	Arncliffe 2205	(02) 9597-7222

# HFAI:TH&HO technologies

**CONTACT INFORMATION:**

**Hearth & Home Technologies  
1445 North Highway  
Colville, WA 99114  
Division of HNI INDUSTRIES**

**We recommend that you record the following pertinent information  
for your heating appliance.**

Date purchased/installed: \_\_\_\_\_

Serial Number: \_\_\_\_\_ Location on appliance: \_\_\_\_\_

Dealership purchased from: \_\_\_\_\_ Dealer phone: \_\_\_\_\_

Notes: \_\_\_\_\_

\_\_\_\_\_

\_\_\_\_\_

This product may be covered by one or more of the following patents: (United States) 5341794, 5263471, 6688302, 7216645, 7047962 or other U.S. and foreign patents pending.

**H EARTH & HOME**  
technologies

7076-260 • January 12, 2015