

# INTERNATIONAL GAS CONVECTOR BOX

**For Zero Clearance Installations**

**THIS MANUAL CONTAINS INSTRUCTIONS  
FOR ASSEMBLY AND INSTALLATION**

Please read this entire manual before you assemble,  
install and use the International Gas Convector Box.



**JETMASTER (VIC) PTY LTD**

ACN 005 872 159 ABN13 659 821 337

444 Swan St. Richmond VIC 3121 PO Box 5051 Burnley 3121

Phone: (03) 9429 5573 Fax: (03) 9427 0031

Website: [www.jetmaster.com.au](http://www.jetmaster.com.au) Email: [info@jetmastervic.com.au](mailto:info@jetmastervic.com.au)

## TABLE OF CONTENTS

<b>SAFETY NOTES</b>	<b>3</b>
Before Installation .....	3
Important Safety Notes .....	3-4
Ventilation Requirements .....	5
<b>PRODUCT INFORMATION</b>	<b>6</b>
Identify Components .....	6
Dimensions .....	7-8
<b>ASSEMBLY</b>	<b>9</b>
Zero Clearance Casing .....	9-10
Assembly of Gather to Convector Box .....	11
Assembly of the Zero Clearance Casing & Convector Box .....	12-13
<b>INSTALLATION</b>	<b>14</b>
Frameout Into Room .....	14
Flush Wall Installation .....	15
Gas Convector Positioning .....	16
Flue Installation .....	16-17
Gas & Power Connection .....	17
Gas Burner Installation .....	17
Flue Termination .....	18
Summary taken from the gas installations Australian standards .....	19
How to fit Fascias .....	20
<b>WARRANTY</b>	<b>21</b>

For Service and Spare Parts contact Jetmaster on (03) 9429 5573.

## **SAFETY NOTES**

### **Before Installation**

The Gas Convector Box shall be installed only by authorised personnel in accordance with the manufacturer's installation instructions, local gas fitting regulations, municipal building codes, electrical wiring regulations, and any other statutory regulations.

Contact local building authorities about restrictions and installation inspections that may be required. If in doubt contact your local dealer or Jetmaster's head office.

### **Important Safety Notes**

- When installing the International Gas Convector Box for Zero Clearance Installations and the Gas Burner, particular attention should be paid to fire protection. If this Gas Convector Box is not properly installed a house fire may result. To reduce the risk of fire, follow these installation instructions and the Gas Burner installation instructions carefully.
- **RISK OF FIRE!** Do not burn materials inside this Gas Convector Box. This is NOT a wood stove and has not been designed for this purpose. Burning materials inside the Gas Convector Box can result in damage to the unit, house fire and/or death.
- Comply with all minimum clearances to combustibles as shown in this manual and in the Gas Burner installation instructions.
- Do not connect to any air distribution duct or system.
- Do not operate without fully assembling all components. Operating your Gas Burner and Gas Convector Box without all the components properly assembled will void your warranty and could present a serious safety hazard.
- An approved gas cowl with a minimum cross-section of 40,000 sq mm must be fitted to the top of the flue or chimney.
- All open gas fires require fixed fresh air vents in the room. See page 5 for ventilation requirements.

. . . continued next page

## **IMPORTANT - PLEASE NOTE**

**Failure of the gas fitter to install the appliance  
as per manufacturer's specifications and in line  
with the Gas Code will void the warranty.**

## **SAFETY NOTES**

### **Important Safety Notes**

**. . . continued**

- **Air movement systems** - A decorative gas log fire must not be installed where the operation of any ventilation system, fan or air blower could under any circumstances cause the air pressure to be less than atmospheric at the appliance, or otherwise adversely affect the operation of the appliance.
- Do not block or restrict chimney or flue opening.
- After installing the appliance, check that the chimney/flue system draws well.
- Jetmaster recommends that all gas fires be serviced every year.
- All gas units must be fitted by a licensed gas fitter.
- It is the responsibility of the gas fitter to follow the regulations set out in the Gas Code that dictate the procedures to follow when installing a gas appliance, particularly regarding gas pipe sizing and checking of pressures. (see summary page)
- For installation of the gas burner, see instruction manual supplied with gas burner.

### **IMPORTANT - PLEASE NOTE**

**Failure of the gas fitter to install the appliance as per manufacturer's specifications and in line with the Gas Code will void the warranty.**

## SAFETY NOTES

### Ventilation Requirements

**ROOMS WITH GAS OPEN FIRES  
REQUIRE FRESH AIR VENTS  
AS PER GAS REGULATIONS**

**FOR EXAMPLE:**

### **1 OFF: WOODFLOW VENT:**

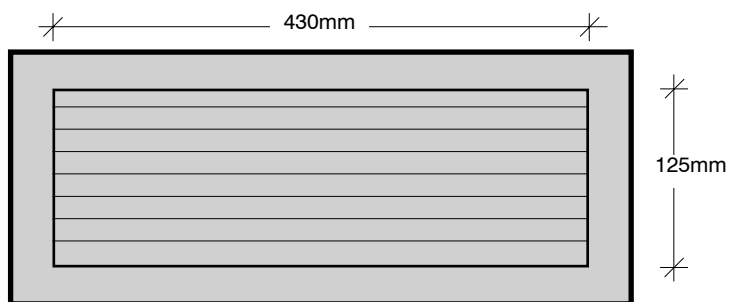

### **OR: 2 OFF VENTS REQUIRED:**



Ventilation - An opening to outside with a minimum free ventilation area of 400 square centimeters shall be provided for each decorative gas log fire.

**Note:** The chimney in which the appliance is installed is not to be considered as a ventilation opening.

# PRODUCT INFORMATION

## Identify Components

The Gas Convector Box for Zero Clearance Installation and Flue Kit components are identified below:

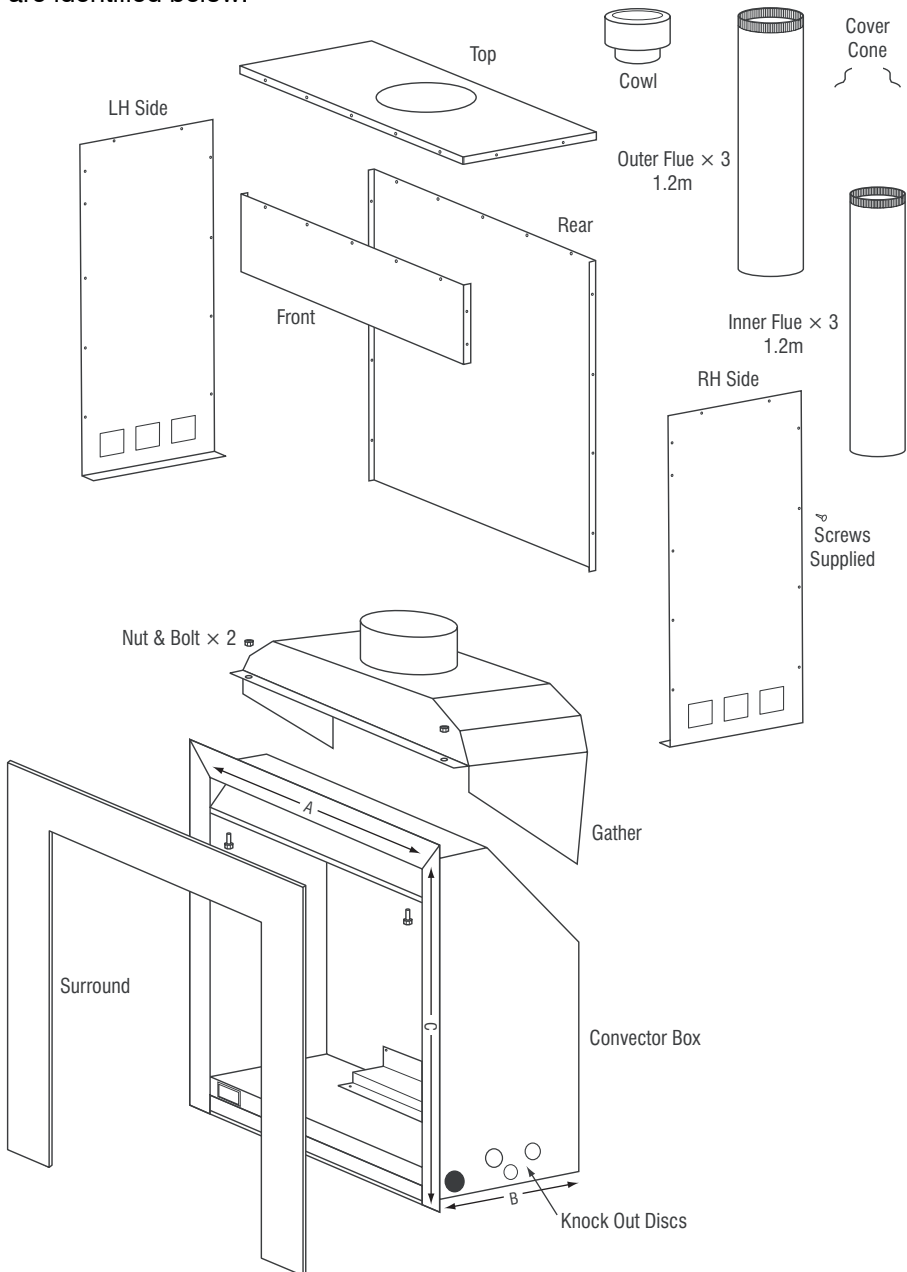

## PRODUCT INFORMATION

### Dimensions

The following tables and diagram show dimensions of the **Gas Convector Zero Clearance Casing** sizes available:

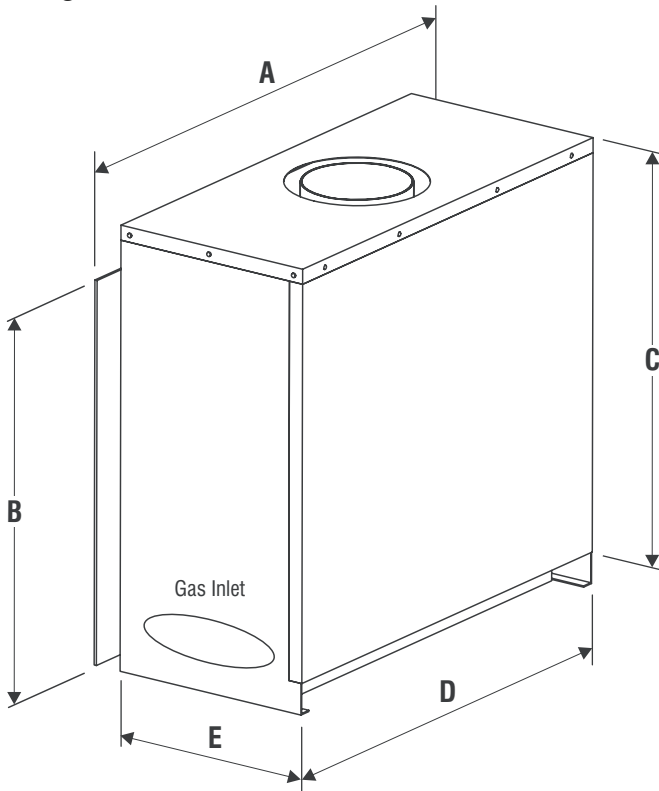

Model	A	B	C	D	E
<b>700</b>	900	700	910	870	425
<b>850</b>	1050	700	910	1020	425
<b>1050</b>	1250	620	825	1220	425

Flue Size		
Model	Inner	Outer
<b>700</b>	200	250
<b>850</b>	250	300
<b>1050</b>	225	275

## PRODUCT INFORMATION

### Dimensions

The following tables and diagram show dimensions of **International Gas Convector Box**:

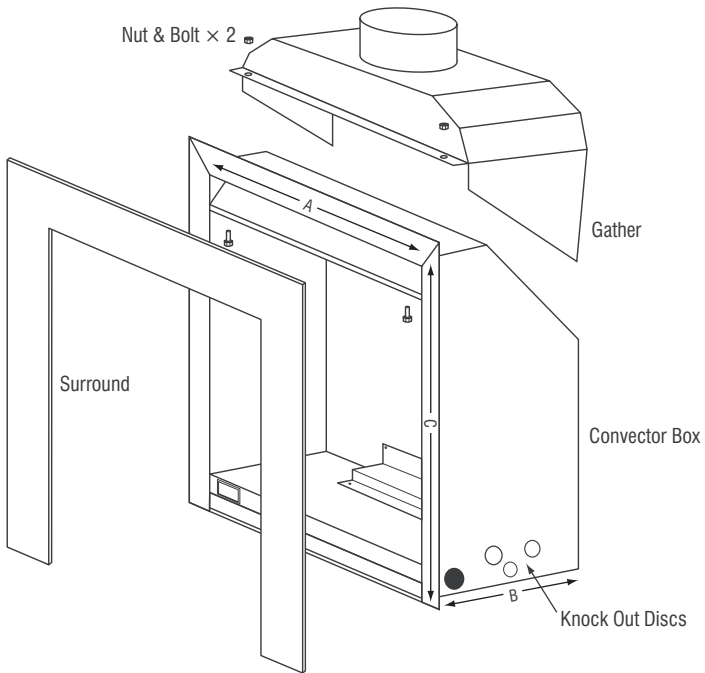

Model	A	B	C
700	800	345	650
850	950	345	650
1050	1150	345	570



## ASSEMBLY

### IGC Zero Clearance with 100mm Trim Installation Instructions



1. Bolt gather onto the top of the IGC, using the bolts provided
2. Slide 100mm trim over the existing 50mm flange of the IGC.
3. Assemble the Zero Clearance casing:

- The casing comes in two pieces. Unfold the side panels of the large piece so that they sit at 90 degrees to the central panel. This forms the back and sides of the Zero Clearance casing. Stand this upright to create the body of the casing. Fold down the tabs around the top of the back and sides.
- Fold the second piece according to the perforations, creating a top and front panel, and a front lip.
- Place the top/front panel over the sides and back of the casing. Line up the holes and attach, using self-tapping screws or pop-rivets.

4. Lift Zero Clearance casing over the IGC and gather and attach using three screws on each side.
5. The IGC Zero Clearance casing with 100mm trim is now complete.



## ASSEMBLY

### Zero Clearance with UK Front Installation Instructions

Ensure that there is sufficient clearance around the IGC and that the IGC is sitting flush with the plaster, to allow the UK front to fit flat and flush with the plaster.

The frame must have a gap of minimum 75 mm from the hearth to allow the convected air to circulate around the IGC.

The use of heat resistant plaster is recommended but not a requirement.

1. Bolt gather onto top of the IGC, using the bolts provided.
2. Slide the sub-frame over the existing 50 mm flange of the IGC.
3. Assemble the Zero Clearance casing.
  - The casing comes in two pieces. Unfold the side panels of the large piece so that they sit at 90 degrees to the central panel. This forms the back and sides of the Zero Clearance casing. Stand this upright to create the body of the casing. Fold down the tabs around the top of the back and sides.
  - Fold the second piece according to the perforations, creating a top and front panel and a front lip.
  - Place the top/front panel over the sides and back of the casing. Line up the holes and attach, using self-tapping screws or pop-rivets.
4. Lift Zero Clearance casing over the IGC and gather and attach using three screws on each side.

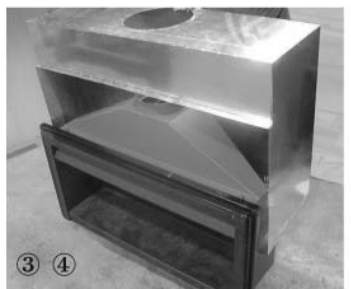

## ASSEMBLY

### Zero Clearance with UK Front Installation Instructions . . . continued

#### 5. Fitting the brackets

**Step 1.** These parts should already be pre-assembled. If not, then screw the R/H top slide bracket to the R/H top fixed bracket using an M8x12mm long screw. Leave the screw slack at this stage so that the top bracket can slide up and down.

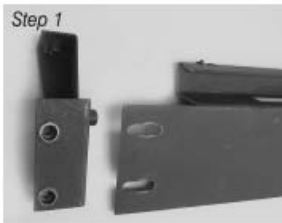

**Step 2.** Locate and bolt both assembled top brackets onto the deflector plate ends. Leave the bolts loose.

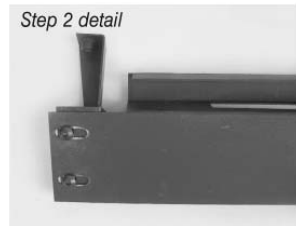

**Step 3.** Mount the deflector plates with brackets onto the sub-frame by pushing the brackets out so that they fix against the sub-frame. Tighten the bolts to fix the deflector plate on to the sub-frame, leaving the top slide brackets loose.



## ASSEMBLY

### Zero Clearance with UK Front Installation Instructions . . . continued

**Step 4.** At this point, slide the top bracket up until it is 1mm above the top of the sub-frame, ensuring that the edge of the top slide bracket is hard up against the front surface of the sub-frame. Check that the left and right hand fixed brackets are located centrally and that the top slide brackets are 1mm higher than the sub-frame and are parallel with the top edge of the sub-frame.



**Step 5.** At this stage, it is easier to fit the gas burner into the firebox.



### 6. Fitting the UK front.

- Before offering up the UK front, ensure that the two lower slide bolts are pushed fully to the centre of the fire so that they do not foul the sub-frame when offering the UK front up to the sub-frame for fitting. If they have moved during transit then slacken the M8x16mm screws and slide the bolts towards the centre. Then re-tighten them. Screw a grub screw just a couple of threads into the end of each slide bolt.
- Now offer up the UK front so that it rests on the top brackets and it locates between the sub-frame. Insert an M8x16mm long screw into each of the top holes of the UK front and screw them hand tight into through, into the top slide brackets.

## ASSEMBLY

### Zero Clearance with UK Front Installation Instructions

... continued

- Now reach through the frame and working from the inside, slacken the two right hand M8x16mm long screws that hold the slide bolts in place. Slide the bolt hard behind the sub-frame, then fully tighten the two M8x 16mm long screws. Repeat with the left hand side. Now carefully tighten the grub screws in the end of the right and lefthand slide bolts so that they push against the inside of the sub-frame, thus pulling in the UK front and clamping it onto the sub-frame.

#### ***DO NOT OVER-TIGHTEN THE SCREWS.***

- Finally return to the screws at the top of the UK front. First ensure that the UK front is located correctly and that the UK front just clears the wall above the fire. Now fully tighten these two top screws.



# INSTALLATION

## Frameout Into Room

The diagrams and table below show dimensional details for constructing a timber frame which protrudes into the room.

Model	A	B	C
700	950	950	450
850	1100	950	450
1050	1300	900	450

Note: Dimension 'B' in the table is measured from the top of the hearth.

When using a Jetmaster fascia allow extra depth to framing.

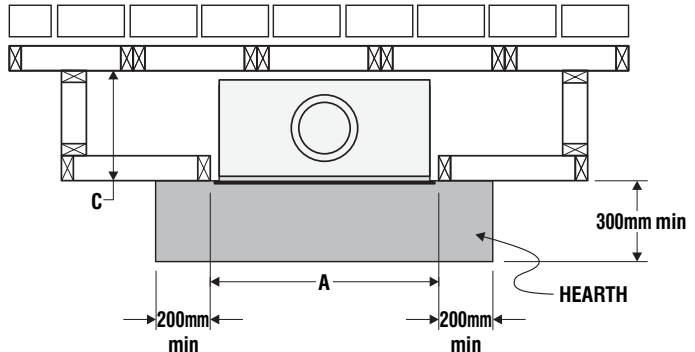
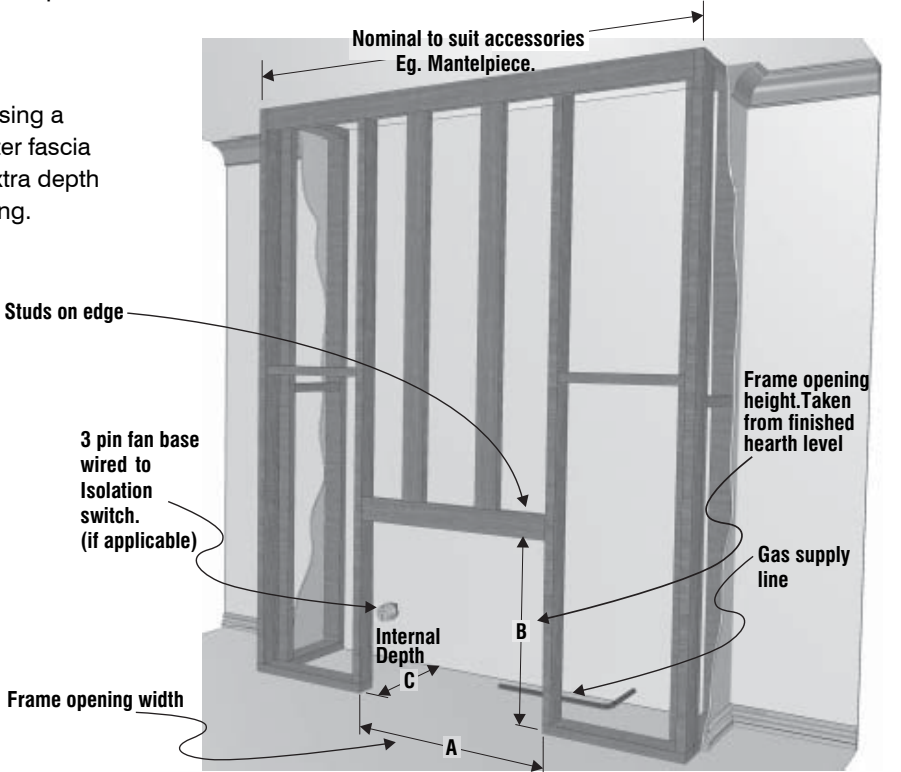

No hearth is required but for added safety a hearth is recommended.

# INSTALLATION

## Flush Wall Installation

The diagrams and table below show dimensional details for constructing a flush wall installation.

Model	A	B	C
700	950	950	450
850	1100	950	450
1050	1300	900	450

Note: Dimension 'B' in the table is measured from the top of the hearth.

When using a Jetmaster fascia allow extra depth to framing.

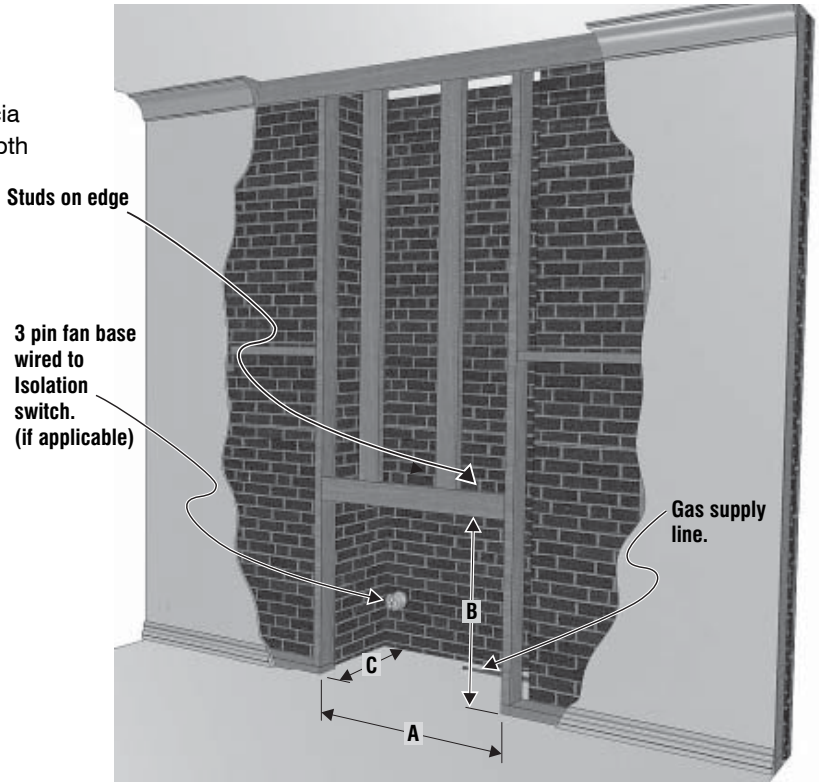

No hearth is required but for added safety a hearth is recommended.

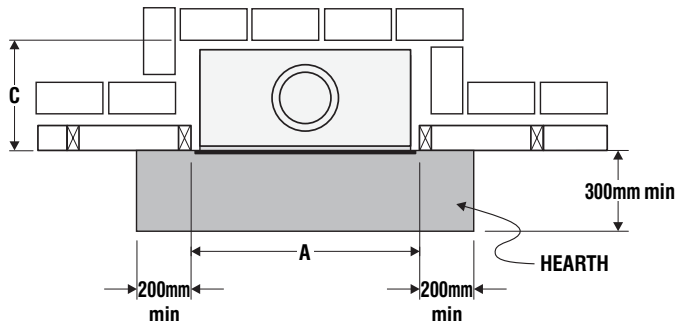

## INSTALLATION

### Gas Convector Positioning

1. Position the Gas Convector and Zero Clearance casing at the same height above the floor as your hearth. (minimum 6mm non-combustible material)
2. Push the Zero Clearance Casing and the Convector Box back into the cutout. Ensure the power cord is not touching the Zero Clearance housing as shown right.
3. Ensure air-intakes at bottom of Gas Convector Zero Clearance Casing are not obstructed.
4. Maintain 25mm clearance from Zero Clearance Casing to combustible material on back and sides.

### Flue Installation

1. This Gas Convector Box must be installed with a minimum of 3 x 1200mm lengths of flue or more as required (see section referring to clearance above roof on page 18 of this installation manual).
2. The flue must fit over the spigot as shown in diagram 1, with the corrugated end of the flue facing upwards. The flue must **NOT** fit inside the spigot, if this is the case then you have an incorrectly sized flue. The corrugated end of the flue should **NOT** be fitted as shown in diagram 2, this is **INCORRECT**.



diagram 1



diagram 2

3. Rivet inner flue to collar of gather at three places.
4. Rivet all further inner flues at three places.
5. Using double skin flues space inner and outer flues using 3 x 25mm self tapping screws through outer casing at bottom, at each join and at top. Also ensure that flues are ventilated at top and bottom, and when using a cover cone drill a series of holes into the outer flue below the cover cone to ensure adequate ventilation.



## INSTALLATION

### Flue Installation

... continued

6. Maintain a clearance of 25mm from outer flue to combustible materials.
7. Flash flue penetration at roofline with appropriate flashing to suit roof material. If using a collar style flashing ensure it is suitable for heat operation.
8. Fit gas cowl. See page 3.
9. Long flue runs will require bracing to nearby framework. Use a non-combustible material such as hoop iron. Brace at 1500mm intervals.
10. The base beneath the unit must be made of non-combustible materials of no less than 6mm. No hearth is required but for added safety a hearth is recommended.
11. Framing
  - a) Construct timber frame, laying studs at face of fireplace on edge.
  - b) Keep clearance from top of unit 25mm.
  - c) Note that depth requirements vary with the use of a cast iron fascia.
  - d) Overall frame width will be determined by size of selected mantelpiece.
12. Plaster
  - a) Firecheck plaster is recommended with installations using a UK front.
  - a) Unit must be installed and flue run PRIOR to plastering.
  - b) The Zero Clearance casing has a location channel for plaster to slot into. This may be the final chosen finish.
  - c) With a cast iron fascia, cut the plaster around the fascia. Keep the face of the plaster and the fascia flush to fit the mantel.

### Gas & Power Connection

To be performed by an authorised person.

1. If applicable, provide an electrical three-pin fan base to the inside back left hand corner of the frame out. Hard wire from this to an external isolating switch generally mounted on the outside of the fireplace recess.
2. Prepare the gas connection as detailed in the Gas Burner Installation Instructions. The gas line is to enter the right hand side of the recess to align with the gas inlet as shown on page 7.

### Gas Burner Installation

Fit your gas burner into the Convectox Box as per the instructions supplied with the gas burner.

# INSTALLATION

## Flue Termination

The Flue Terminal shall be located so that wind from any direction is not likely to create a downdraught in the flue. A Flue Cowl, AGA Approved to AG604 must be fitted to the end of the flue pipe. The minimum flue length must not be shorter than 3.5 metres. Maintain a minimum of 500mm from the bottom of the flue cowl to the nearest part of the roof if the flue cowl is at least 1m from a neighbouring structure. If less than 1m, the flue terminal must be located at least 500mm above that structure. Refer to AS5601 - 2000 (AG601) sections 5.13.6.2 and 5.13.6.4 to ensure that the location of the flue terminal fully complies for installations with a trafficable roof, a chimney, another flue terminal or near any openings into a building.

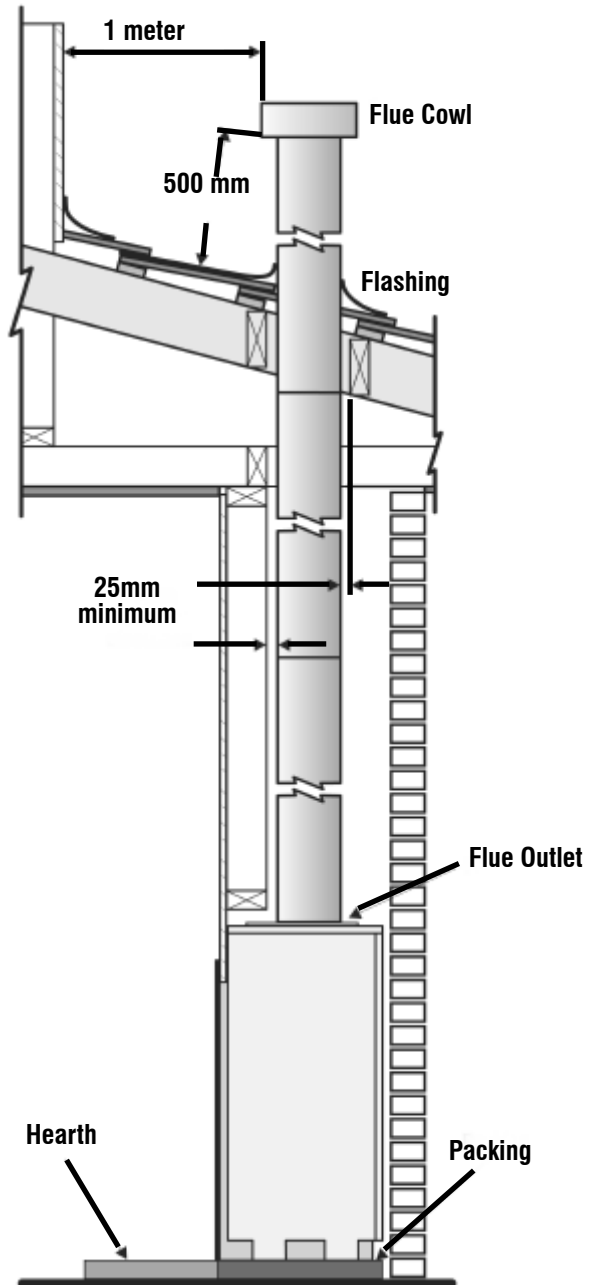

## **SUMMARY**

### **SUMMARY TAKEN FROM THE GAS INSTALLATIONS AUSTRALIAN STANDARDS AS5601-2002 AG601-2002**

**IMPORTANT:** THIS IS A SUMMARY ONLY. THE GAS FITTER MUST REFER TO THE GAS INSTALLATIONS AUSTRALIAN STANDARDS IN DETAIL.

#### **Appendix F Sizing Consumer Piping**

##### **- New Consumer Piping Systems**

When sizing a new consumer piping system, consideration should be given to foreseeable future needs.

##### **- Existing Consumer Piping Systems**

When an additional appliance is to be connected to an existing consumer piping system, the existing piping, metre and regulator should be checked to ensure that adequate capacity is available for the additional load.

##### **- Information Required Prior To Pipe Sizing**

The following information is required prior to pipe sizing:

- a. The type of gas, including the heating value and relative density.
- b. The gas consumption of each appliance.
- c. An allowance, if any, where there is a probability that not all appliances will be used at the same time.
- d. The pressure available at the start of the consumer piping.
- e. The allowable pressure drop shall be such as to ensure that at least the minimum inlet pressure required by the appliance is available at the appliance.
- f. The proposed layout of the consumer piping system including all pipe lengths and the location of each appliance.

NOTE: See tables in this appendix

# INSTALLATION

## HOW TO FIT FASCIAS

1. Use lugs and bolts provided and attach to flange on firebox.

**OR**

2. Use masonry plugs and drill through corners of fascia and attach to bricks.

**OR**

3. If neither of the above is suitable, then use heat resistance bonding silicon.

**Note:** Mantelpiece will hold fascia in position.

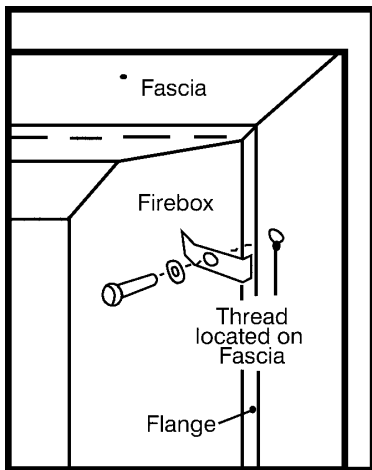

### 100mm Stainless Steel Trim Method for Attachment

1. Score the back of the stainless steel trim and the surface to which the trim will be attached, to allow the two surfaces to adhere well to each other.
2. Place a bead of Silicone onto the back of the stainless steel trim.
3. Place another bead of Liquid Nails around the outer edge of the frame. This will cure quickly and hold the frame into position.
4. Clamp the trim onto the unit for 24 hours until the adhesives have cured.

## WARRANTY

Provided the Jetmaster Gas Convector Box is installed according to Jetmaster instructions and a Jetmaster Gas Burner is used, the unit\* is unconditionally guaranteed for a period of 10 (ten) years from the date of installation of the fireplace.

\*Not including glass doors, gas burner or fan.

## INSTALLER'S NOTE:

**Please discuss all relevant safety issues with the owner and pass the operating instructions on to the owner after the installation has been tested and signed off by the local municipality as a safe installation.**



**Jetmaster (Pty) Ltd.**

## AUSTRALIA

Melbourne:  
444 Swan Street  
Tel: +61 (03) 9429 5573  
Fax: +61 (03) 9427 0031

Sydney:  
10 Martin Avenue Arncliffe  
Tel: +61 (02) 9597 7222  
Fax: +61 (02) 9597 7622

## NEW ZEALAND

Auckland:  
12 Tawari Street  
Mt Eden  
Tel: +64 (09) 623 6996  
Fax: +96 (09) 623 6997

## SOUTH AFRICA

Gauteng:  
1316 Clubhouse Street  
Maraisburg, Johannesburg  
Tel: +27 (011) 474-2100/4  
Fax: +27 (011) 474-2144  
[www.jetmaster.co.za](http://www.jetmaster.co.za)

## NOTES

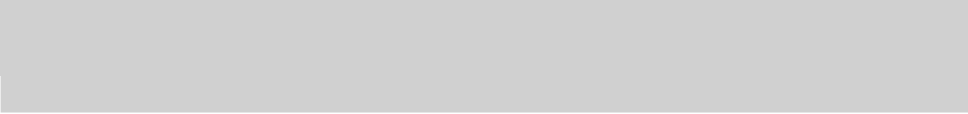



## **JETMASTER (VIC) PTY LTD**

ACN 005 872 159 ABN13 659 821 337

444 Swan St. Richmond VIC 3121 PO Box 5051 Burnley 3121

Phone: (03) 9429 5573 Fax: (03) 9427 0031

Website: [www.jetmaster.com.au](http://www.jetmaster.com.au) Email: [info@jetmastervic.com.au](mailto:info@jetmastervic.com.au)